

Product Description

The LumenRadio MWA-N3 (Third generation Mira Wide Area) module is an industrial grade, long-range, multi-standard radio module, designed for high volume production.

MWA-N3 has an improved link budget due to a new state of the art RF-frontend design. The improved link budget results in longer operational range possible compared to MWA-N2.

An onboard antenna option has been added to the MWA-N3 and selecting between onboard and external antenna is easily done in firmware. MWA-N3 is based on the Nordic Semiconductor nRF52840 and features a powerful ARM Cortex M4 microcontroller and a dual radio for Bluetooth-based protocols and 802.15.4-based protocols. MWA-N3 is optimized for running MiraOS and the MiraMesh radio stack.

The MiraOS, MSS (Multi-Standard Support) feature allows concurrent operation of MiraMesh and Bluetooth v5.0, as well as 802.15.4 based protocols. This feature provides reliable mesh networking through MiraMesh with concurrent support for easy commissioning, local control and user interaction (UX/UI) over Bluetooth v5.0/NFC using a smartphone or tablet. Ultra-low energy consumption allows for battery powered products or energy harvesting operation. MWA-N3 is an SMD module and thanks to its small footprint it can be easily integrated into any product.

Best-in-class range (up to 1500m line-of-sight), thanks to the improved built-in power amplifier (PA) and low noise amplifier (LNA).

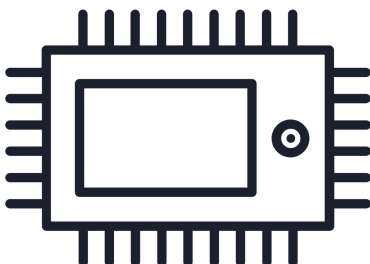

Features

- Optimized for MiraOS operation
- Based on Nordic Semiconductor nRF52840 chipset
- External antenna connector interface
- Onboard antenna option
- Automated PA and LNA control for ultra-long range operation.
- Concurrent Bluetooth operation
- NFC-A support
- ARM Cortex-M4F at 64 MHz operation
- 1 MB flash and 256 kB RAM
- AES 128-bit ECB/CCM/AAR hardware accelerator
- 12bit ADC, SPI, I2C, UART, PWM, USB 2.0, GPIO
- Pre certified for Europe (ETSI RED), US (FCC/CFR 47 Part 15 unlicensed modular transmitter approval), Canada (IC RSS)

Specifications

- Range: up to 1500 m free line of sight between two devices.
- External antenna connector RF Output: Max 19.5 dBm
- Sensitivity: -96 dBm
- 115.5 dB link budget
- u.FL/IPEX external antenna connector
- Frequency band: 2.45 GHz, ISM band (2402-2480 MHz)
- Supply voltage range 3.0 – 3.6 V
- Peak average current consumption 150 mA in high power mode.
- -40 – +75 °C operating temperature
- Dimensions: 33.5 x 18.5 x 3.8 mm

Contents			
Specifications	3	Antennas	19
Absolute maximum ratings	3	Cable handling	19
Recommended operating conditions	3	Antenna Placement	20
Digital I/O pins	3	Recommended antennas	21
RF performance	4	Power supply recommendations	27
Pin assignments	5	Mechanical specification	28
Pin functions	5	Module packaging	30
RF antenna connector	6	Carrier tape dimensions	30
Common mistakes	7	Reel marking	31
Layout considerations	8	Reflow soldering specification	32
MWA-N3 OEM module pad dimensions	8	Product verification guideline	33
Layout considerations for the main board	8	FCC information	33
Guidelines for optimal performance for the internal antenna	9	Industry Canada statement	33
Internal antenna radiation pattern	11	CE	34
Center frequency: 2402 MHz	12	Other compliances	34
Center frequency: 2480 MHz	16	RoHS / REACH	35
		Radio validation tool	35
		Contact and ordering information	35

Specifications

- RF Output: Max 19.5 dBm
- Sensitivity: -96 dBm
- 115.5 dB link budget
- u.FL/IPEX external antenna connector
- Frequency band: 2.45 GHz, ISM band (2402-2480 MHz)
- Dimensions: 33.5 x 18.5 x 3.8 mm

Absolute maximum ratings

Maximum ratings are the extreme limits to which the MWA-N3 module can be exposed for a limited amount of time without permanently damaging it. Exposure to absolute maximum ratings for prolonged periods of time may affect the reliability of the device.

Symbol	Parameter	Min.	Typ.	Max.	Unit
VDD	Supply voltage	-0.3		3.9	V
TA	Operating temperature	-30		75	°C
VIO	IO Input voltage $VDD \leq 3.6V$			$VDD + 0.3$	V
VIO	IO Input voltage $VDD > 3.6V$			3.9	V
VSS	Ground pad voltage			0.0	V
TS	Storage temperature	-40		+125	°C
RFin	RF input power			+10	dBm
ESD	ESD all pins, Human Body Model			1	kV

Recommended operating conditions

Symbol	Parameter	Min.	Typ.	Max.	Unit
VDD	Supply voltage	3.0	3.3	3.6	V
Vrise	Supply rise time (0 V to 3.7V)			60	ms
IDD	Supply peak current capability		150	250	mA

Please see Power supply recommendations for a more specific guideline.

Digital I/O pins

Symbol	Parameter	Min.	Typ.	Max.	Unit
VIL	Input voltage logic low	0		$0.3 \cdot VDD$	V
VIH	Input voltage logic high	$0.7 \cdot VDD$		VDD	V
VOL	Output voltage logic low	0		0.4	V
VOH	Output voltage logic high	$VDD - 0.4$		VDD	V

RF performance

RF performance below is valid at an ambient temperature of 25°C and a supply voltage of 3.3 V.

Symbol	Parameter	Min.	Typ.	Max.	Unit
f-range	Operating frequency range	2402		2480	MHz
RXsens	Receiver sensitivity (0.1%BER)		-96		dBm
TXpout	Transmitter output power		19.5		dBm

Pin assignments

Pin functions

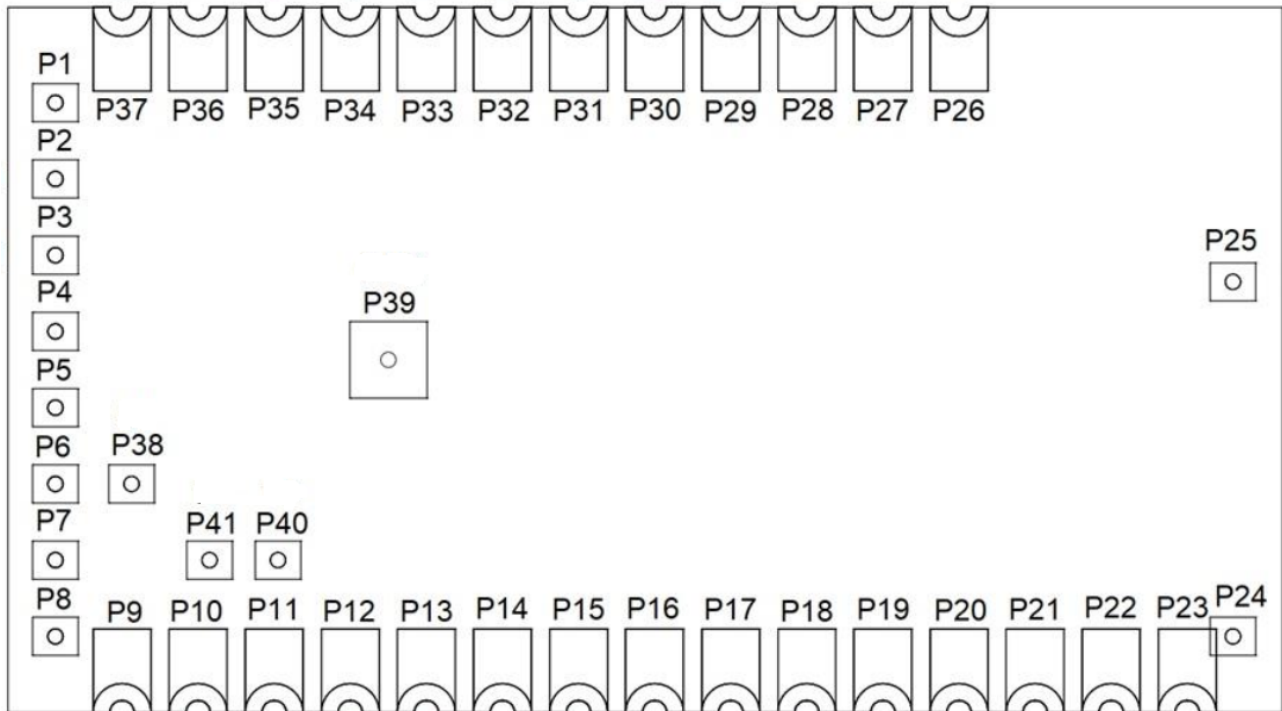

Top view of the module's bottom side.

No	Name	Type	Description
P1	VSS	Power	Ground (0V)
P2	P0.04/AIN2	Digital I/O, Analog Input	
P3	P0.05/AIN3	Digital I/O, Analog Input	
P4	P0.06	Digital I/O	
P5	P0.08	Digital I/O	
P6	P1.08	Digital I/O	
P7	VSS	Power	Ground (0V)
P8	P1.09	Digital I/O	
P9	VSS	Power	Ground (0V)
P10	P0.12	Digital I/O	
P11	P0.11	Digital I/O	
P12	P0.18/nRESET	Digital I/O, Configurable as system RESET	
P13	p0.20	Digital I/O	
P14	P0.22	Digital I/O	
P15	P0.23	Digital I/O	
P16	P0.24	Digital I/O	
P17	P1.0	Digital I/O	
P18	P0.10/NFC	Digital I/O, NFC antenna connection	Low frequency I/O
P19	P0.09/NFC	Digital I/O, NFC antenna connection	Low frequency I/O

No	Name	Type	Description
P20	SWDIO	Serial wire debug I/O (debug and programming)	
P21	SWDCLK	Serial wire debug I/O (debug and programming)	
P22	P1.02	Digital I/O	
P23	VSS	Power	Ground (0V)
P24	VSS	Power	Ground (0V)
P25	VSS	Power	Ground (0V)
P26	VSS	Power	Ground (0V)
P27	VSS	Power	Ground (0V)
P28	P1.13	Digital I/O	Low frequency I/O
P29	P1.15	Digital I/O	Low frequency I/O
P30	P0.03/AIN1	Digital I/O, Analog Input	Low frequency I/O
P31	P0.02/AIN0	Digital I/O, Analog Input	Low frequency I/O
P32	P0.28/AIN4	Digital I/O, Analog Input	Low frequency I/O
P33	P0.29/AIN5	Digital I/O, Analog Input	Low frequency I/O
P34	P0.30/AIN6	Digital I/O, Analog Input	Low frequency I/O
P35	P0.31/AIN7	Digital I/O, Analog Input	Low frequency I/O
P36	VDD	Power	Supply (3.3V)
P37	VSS	Power	Ground (0V)
P38	VBUS	Power	5V input for USB 3.3V regulator
P39	VSS	Power	Ground (0V)
P40	D+	USB Data+	
P41	D-	USB Data-	

Note: Low frequency I/O is a signal with a frequency up to 10 kHz.

For detailed information about pin functionality, see the Nordic Semiconductor nRF52840 product specification document.

RF antenna connector

The antenna connector of the module is a u.FL type. The antenna shall have a characteristic impedance of 50 ohm at 2.45GHz. See the Antennas section for more information.

Common mistakes

The integration of the MWA-N3 module is straightforward, but for optimal RF performance it is important to follow the power supply and layout considerations. Failure to do so may result in inferior RF performance. Some important highlights to avoid the most common mistakes are shown below:

- The carrier PCB shall be of the recommended type and have a proper ground plane
- Product enclosure and carrier PCB shall adhere to the clearance recommendations
- Product enclosure shall not block radio-signals
- Power supply pins shall have sufficient decoupling
- All ground pins shall be available on the carrier PCB
- SWDIO and SWDCLK pins shall be accessed for programming

Layout considerations

Electrical and mechanical design files are available for download at the LumenRadio online support page.

MWA-N3 OEM module pad dimensions

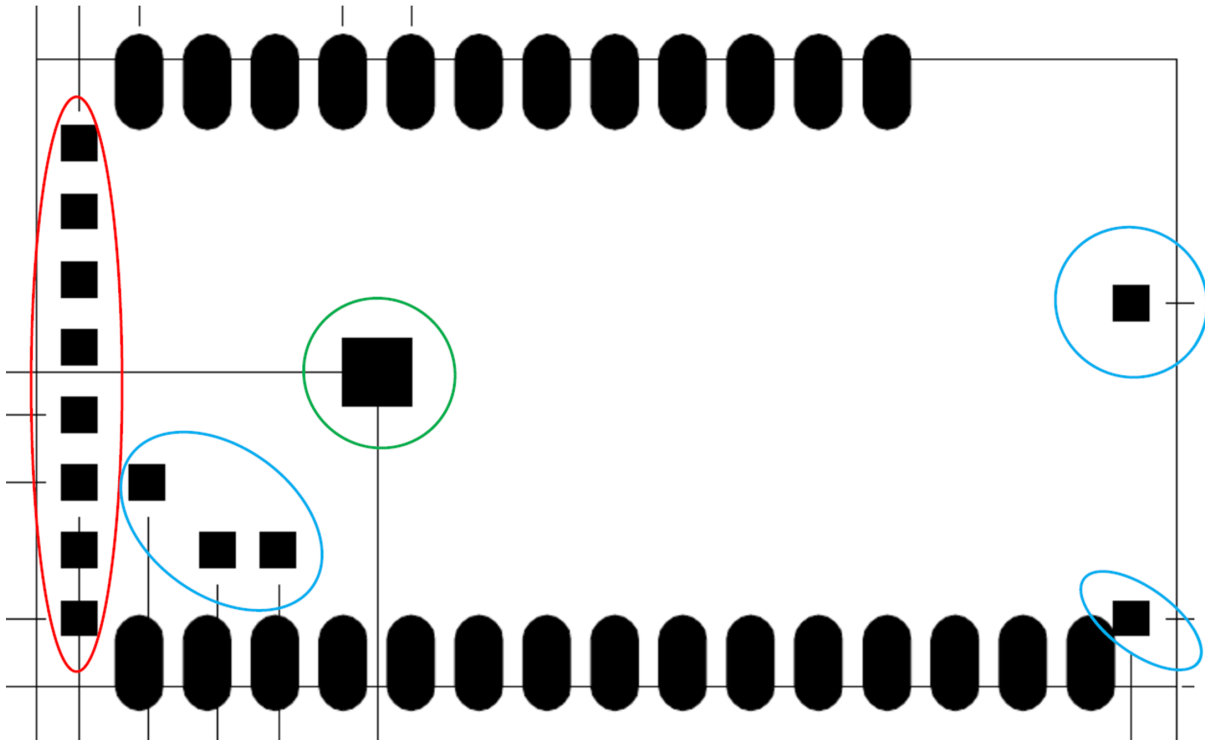

Refer to the picture above. All units in mm.

- Oblong 1.4 x 2.79 (oblong edge a half circle with diameter 1.4)
- Small rectangles left edge 1.0 x 0.8 (red)
- Small squares right edge 1.02 x 1.02 (blue)
- Large square 2.0 x 2.0 (green)

Layout considerations for the main board

The MWA-N3 module has been specifically designed to achieve optimal RF performance. To maintain this, there are some important guidelines that is recommended to follow:

- The use of ground planes also on the carrier board for the MWA-N3 module cannot be emphasized enough. Good decoupling of any high-speed digital circuitry utilized on the carrier board is a must. Many embedded type microprocessors today have clock frequencies with clocks or overtones that reach well into the GHz range. It is possible for an embedded design to pass any EMC certification and still cause disturbances that will block the RF reception of the MWA-N3 module. The sensitivity of the MWA-N3 receiver is -96dBm therefore it is recommended to keep disturbances below -100dBm in the frequency range of operation. A near field probe connected to a spectrum analyzer will show if there are any disturbances present on the 2.45 GHz band generated by the microprocessor or any other device that is placed on the main board. Pay special attention to readymade LAN-products "Server in a RJ connector". They pass EMC certifications, but some of them radiate

badly on 2.45 GHz. If disturbances can be seen on a spectrum analyzer - then the MWA-N3 module will have impaired reception.

- MWA-N3 OEM module has a supply voltage decoupling on the circuit board. The supply voltage still needs to be adequately filtered. If any disturbance or intermittent communication failures occur, as one of the troubleshooting steps; check the supply voltage for drop-outs, switch supply ripple etc.
- The top layer of the carrier board PCB under the MWA-N3 module should be free from copper, non isolated GND planes, traces or vias as indicated in drawing below. The white solid line represents the MWA-N3 module board outer edge. There is a ground plane on the MWA-N3 module bottom layer, but there are also supply lines. It is an unnecessary risk to rely on solder mask lacquer for isolation. Minimum dimensions for ground plane clearance for optimum antenna performance are shown below.

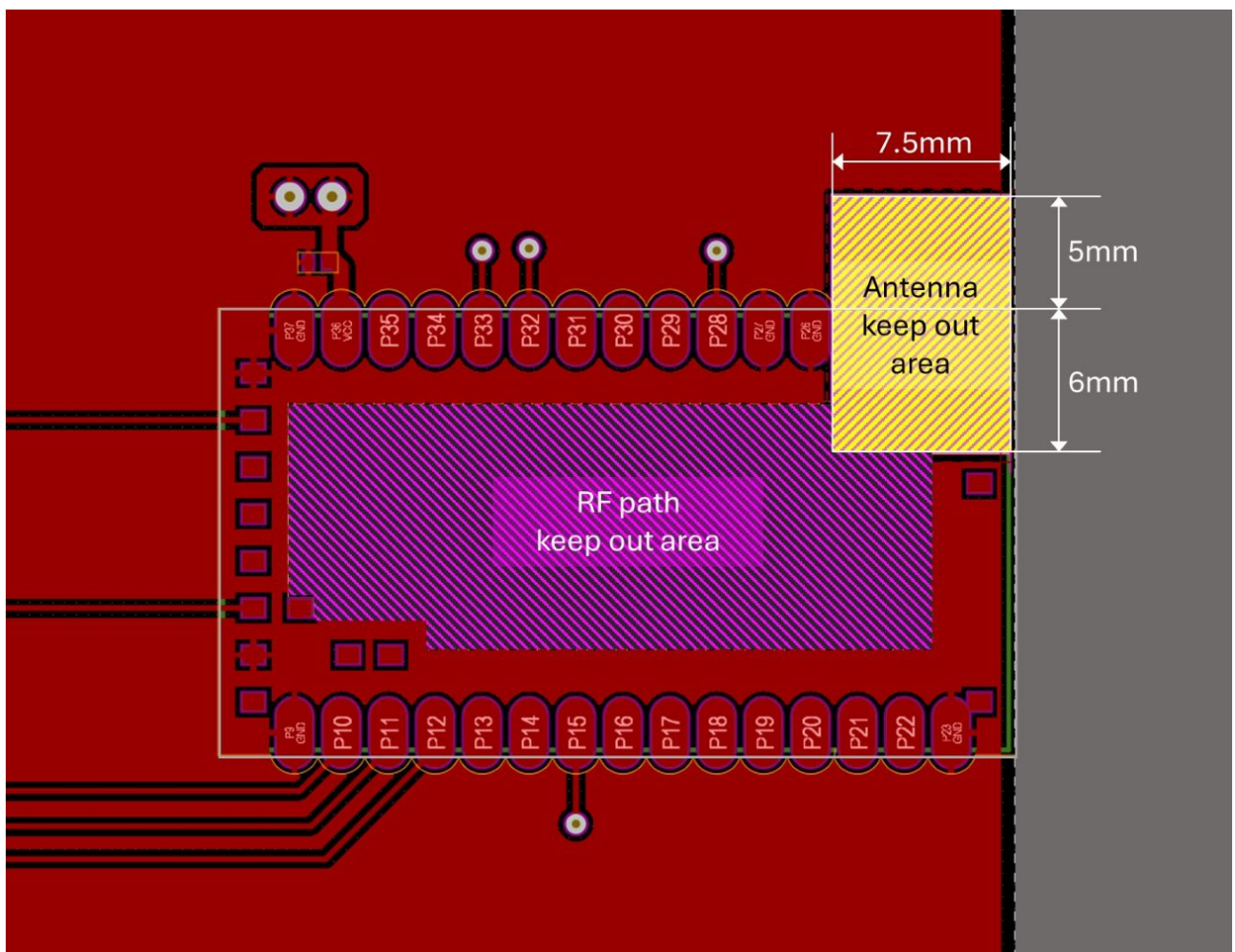

Guidelines for optimal performance for the internal antenna

It is important to consider the guidelines for the internal antenna. Failure to do so may result in inferior performance. The MWA-N3 module has been tested on 1.6mm carrier boards of the brands ITEQ IT180 and Isola 370HR. For optimal performance it is recommended to use those for the carrier board design or a PCB with similar specification. The MWA-N3 module board edge shall align with the carrier PCB edge, and the area within the orange rectangle shall be free from any traces copper, or components on all carrier PCB layers.

The area marked with the striped -pattern is a keep-out area for any solid material including carrier board PCB material.

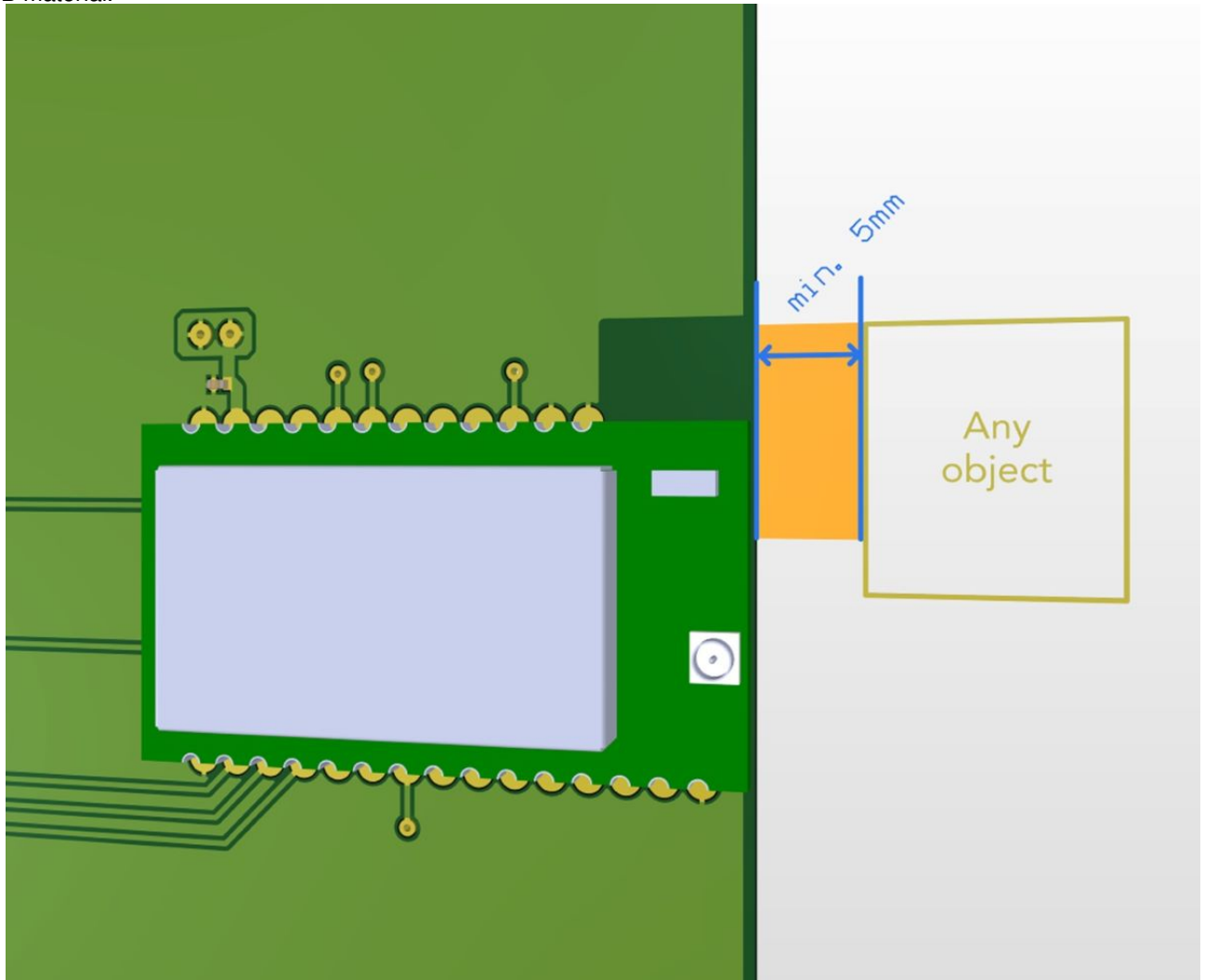

The keep-out area extends from the module PCB surface in the vertical directions as well. Note that the carrier board thickness can be included in the total distance below the module, so that given a 1.6mm carrier board, its standoff shall be minimum 3.4mm.

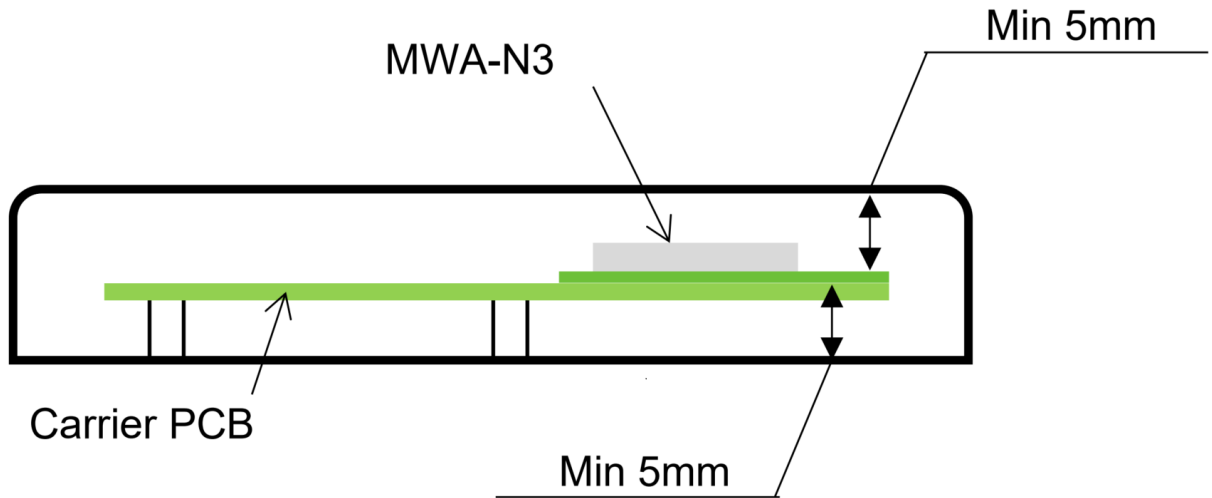

Internal antenna radiation pattern

General Specification	
Frequency (MHz)	2400-2500
Peak gain (dBi typ)	0.5
Impedance	50 Ohm

Center frequency: 2402 MHz

Antenna laying down, horizontal polarization measurement

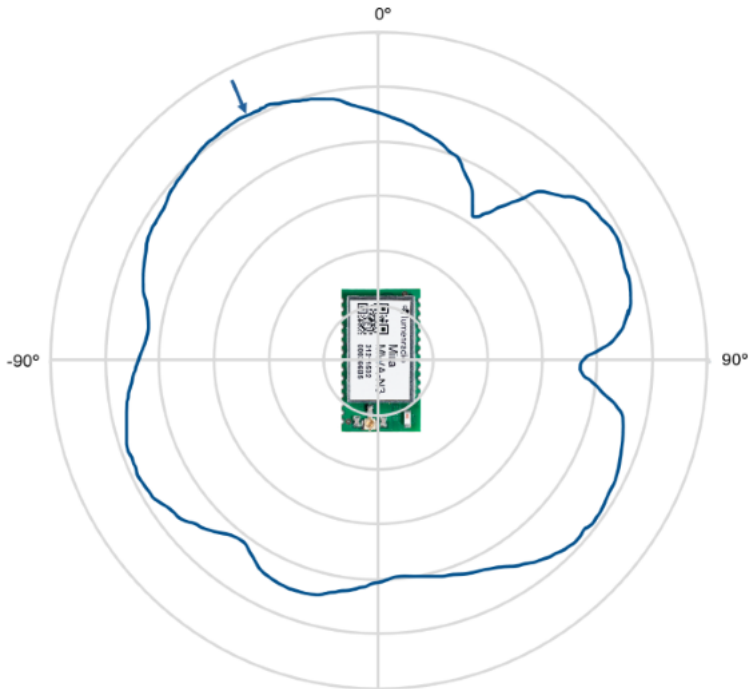

Max: -1.9 dBm

MWA-N3 OEM module integration documentation

Antenna laying down, vertical polarization measurement

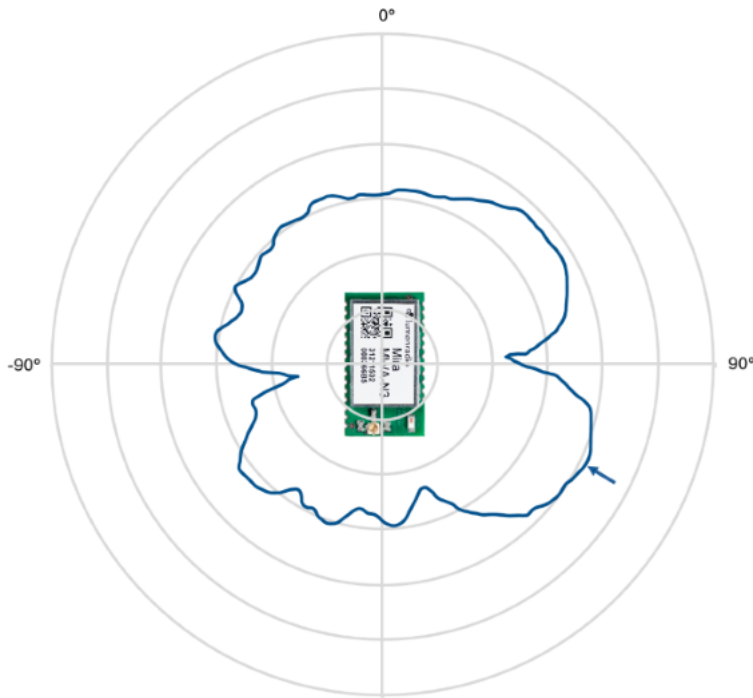

Max: -12.2 dBm

MWA-N3 OEM module integration documentation

Antenna Upright, horizontal polarization measurement

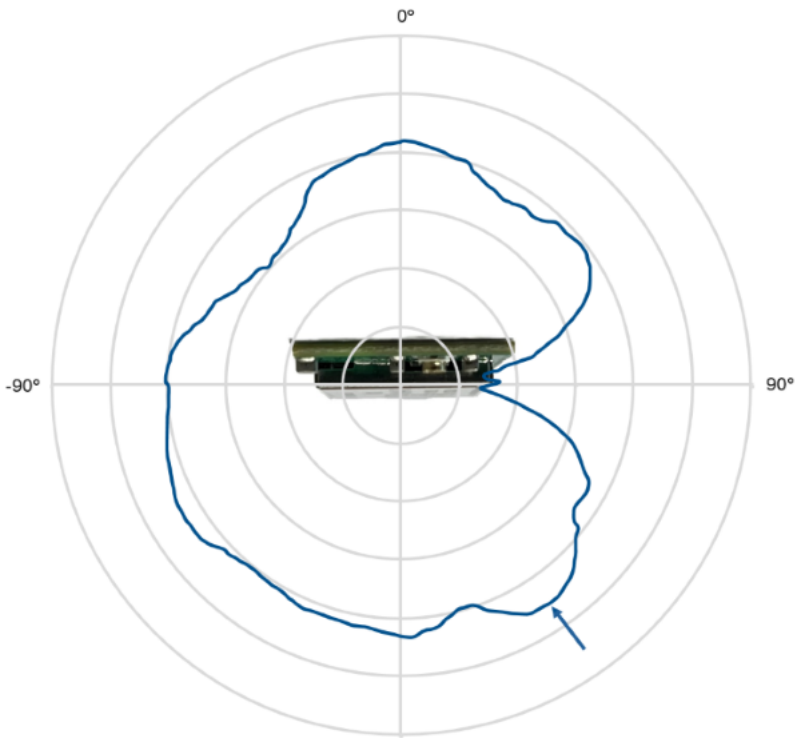

Max: -7.4 dBm

Antenna Upright, vertical polarization measurement

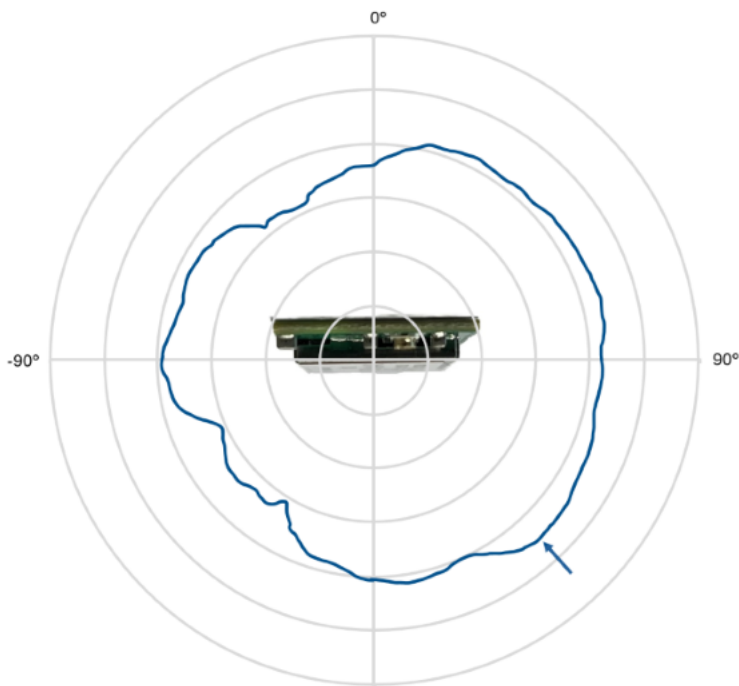

Max: -8.6 dBm

Center frequency: 2480 MHz

Antenna laying down, horizontal polarization measurement

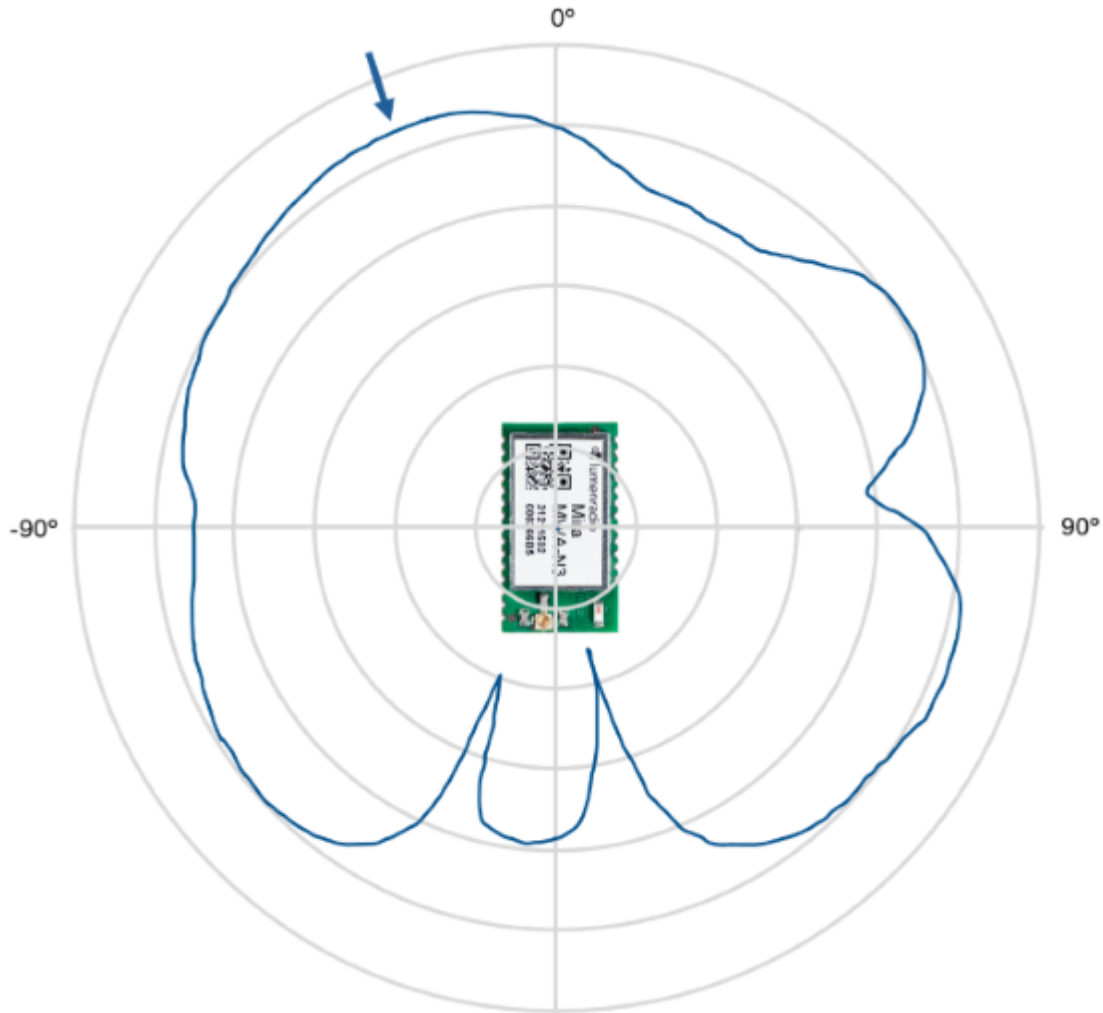

Max: 0.5 dBm

Antenna laying down, vertical polarization measurement

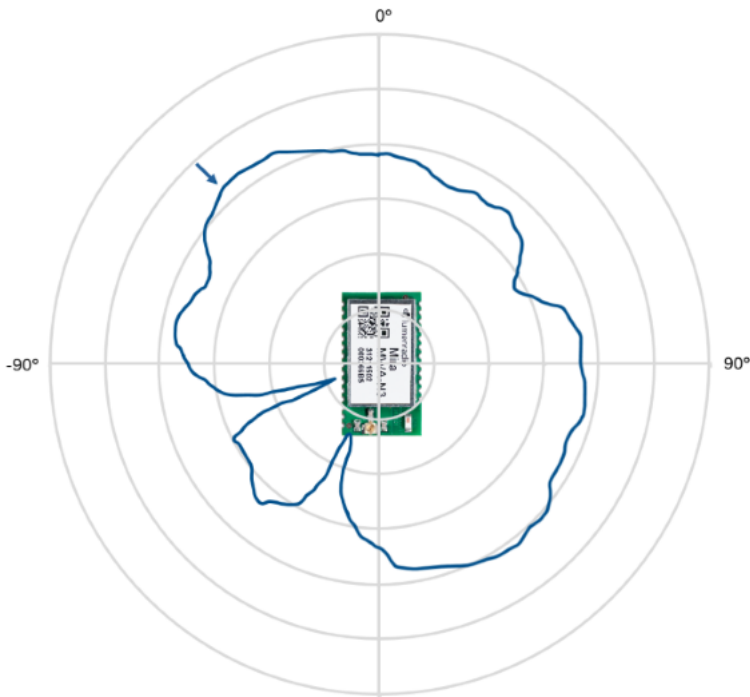

Max: -10.8 dBm

Antenna Upright, horizontal polarization measurement

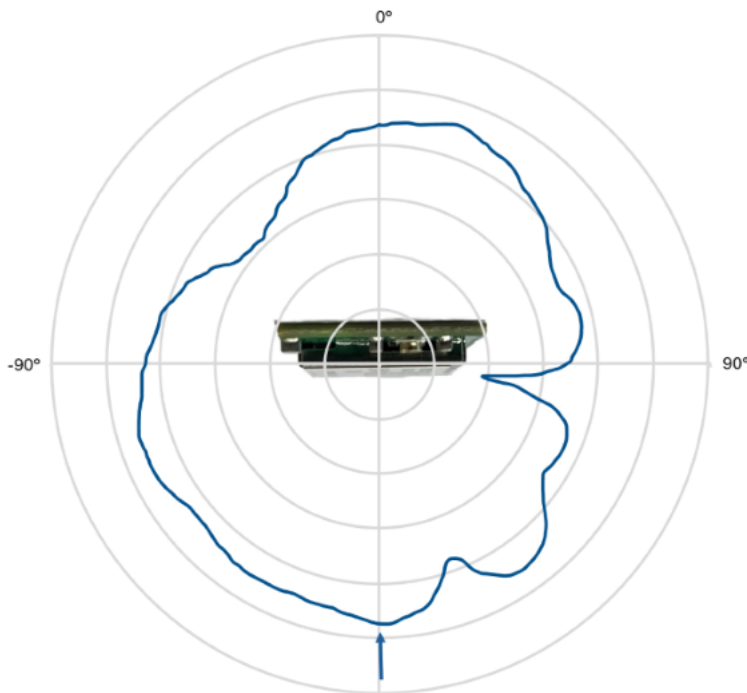

Max: -5.6 dBm

Antenna Upright, vertical polarization measurement

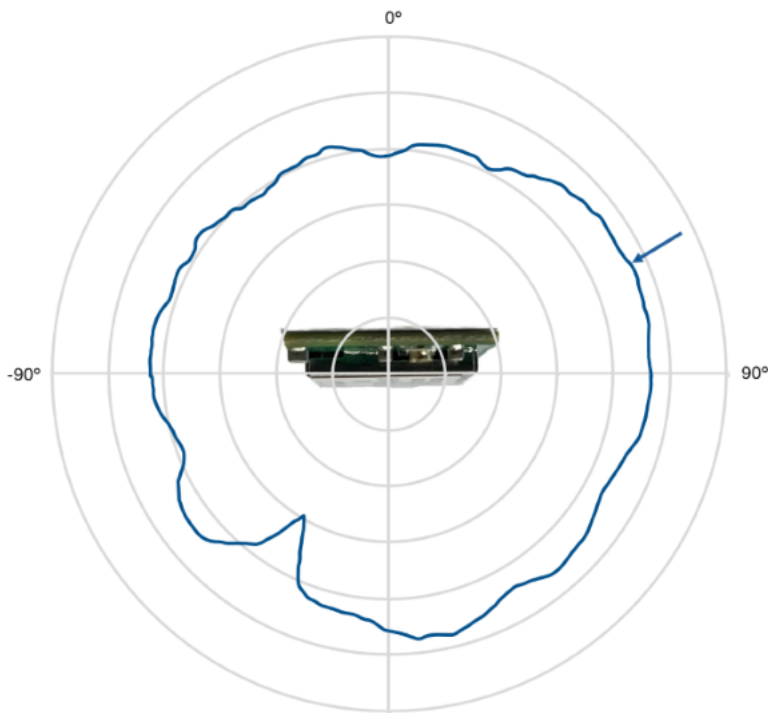

Max: -6 dBm

Antennas

Antenna selection and design is most crucial to achieve satisfactory RF performance of your product. It shall be selected for narrow bandwidth, for use in the 2.4G ISM band (2.4-2.48 GHz) and have minimum loss (typically expressed in S11 parameter or VSWR).

The antenna shall be mounted according to the manufacturer's data sheet. Most antenna types are not completely omni-directional, observe the antenna's radiation pattern when placing/positioning the antenna, so that it is most efficient in the wanted directions.

The antenna can be either of the kind that is terminated with a connector, usually TNC or SMA type. Then you will need a cable assembly like the one below to connect the antenna to module's on-board I-PEX/U.FL connector:



Or it can be equipped with a cable assembly terminated with I-PEX/U.FL connector, which will mate with the RF connector on the module.

Cable handling

The RF path between the module and the antenna is maybe as important as the antenna itself. It shall be a transmission line of 50 ohm impedance and all cables and connectors being part of the transmission line shall be handled with care. To most possible extent, avoid twisting and bending of the cable:



The onboard U.FL/I-PEX connector requires some attention to get a good mating, ensure it is snapped in place, but avoid using force.



IMPORTANT NOTE:

The U.FL/I-PEX connector is surrounded by three isolation capacitors to ensure galvanic isolation between the antenna and the radio module. Be mindful of cable orientation so that no accidental short path is created between the U.FL connector shield and GND or signal pads of the capacitors, as this may result in electrical interference, damage to the equipment, or compromised system performance.

Antenna Placement

A general rule is to allow as much clearance and free space around the antenna as possible. Any object within the path of radiation will interfere or effect the RF performance.

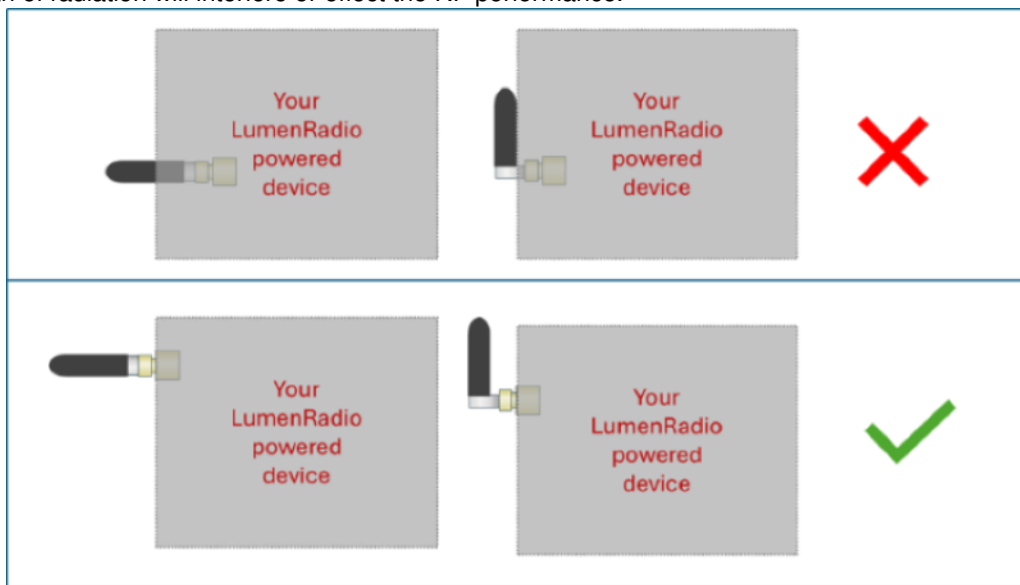

If using a patch type (stick on) antenna, it shall be mounted on plastic (preferably PC/ABS if not stated differently by manufacturer), and have proper clearance to surrounding objects, especially ground planes and other metallic objects. If possible, keep any parallel surfaces free from metallic objects. E.g. if the PCB is placed right underneath the antenna surface, keep that area free from copper and components. At least apply minimum clearance distances as shown below:

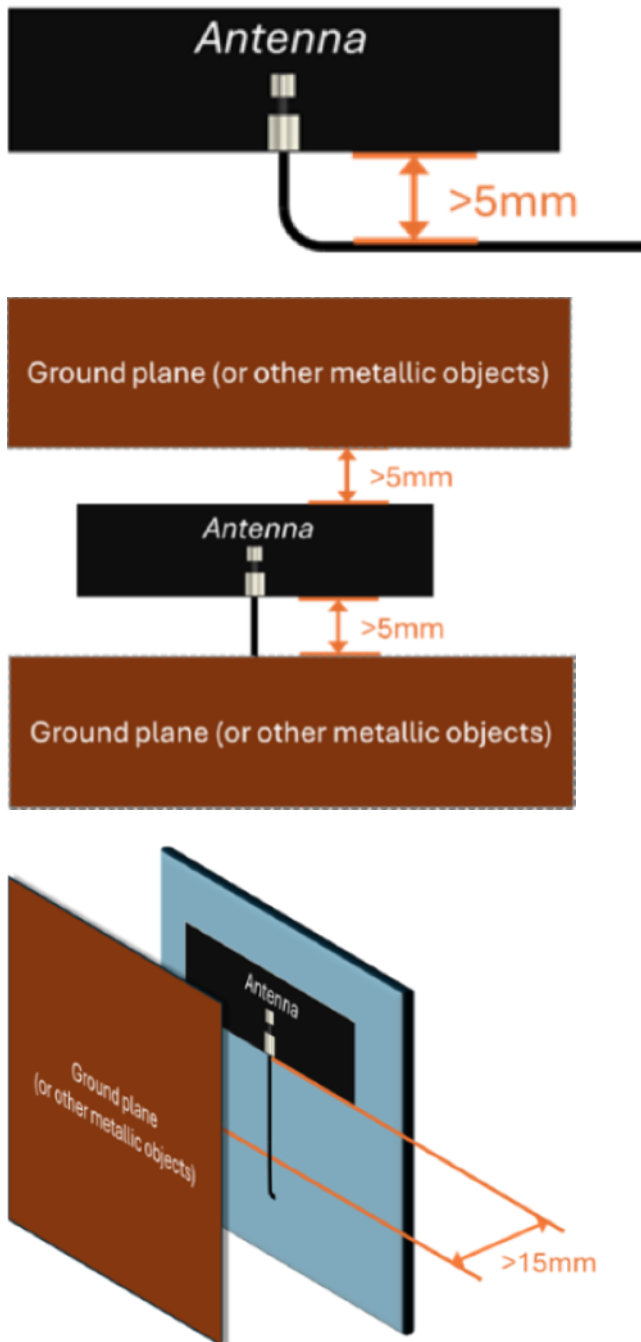

Recommended antennas

For the use in the European market, please be cautious when selecting an antenna to ensure that the output power does not exceed 20 dBm as required by European market regulations.

The MWA-N3 has been tested against FCC and IC regulatory requirements and is approved with the following antennas (or electrically equivalent antennas):

LumenRadio, 2.15 dBi dipole omnidirectional antenna

The LumenRadio 2.15 dBi dipole omnidirectional antenna delivers outstanding performance and orientation flexibility. The antenna can be tilted and swiveled and comes with a rugged RP-TNC connector. Together with MWA-N3 the total maximum radiated power is 21.65 dBm (146.2 mW).

Electrical Specifications	
Frequency Range	2400-2483.5 MHz
Gain	2.15 dBi
V.S.W.R	<2
Nominal Impedance	50 Ohm
Polarization	Vertical
Max Power	25 W
Connector	RP-TNC
Length	144 mm
Random material	TPEE
Random Color	Black

LumenRadio order code: 104-1001



Molex, 3.2 dBi balanced flex antenna

The molex 3.2 dBi balanced flex antenna is an adhesive omnidirectional flexible antenna. The antenna comes with a 50 mm long cable terminated with a U.FL/ I-PEX MHF connector. Together with MWA-N3 the total maximum radiated power is 22.7 dBm (186.2 mW).

Electrical Specifications	
Frequency Range	2400-2483.5 MHz
Gain	3.2 dBi
Return Loss S11 (dB)	<-10
Nominal Impedance	50 Ohm
Polarization	Linear
Connector	U.FL/ I-PEX MHF Connector

Electrical Specifications

Length	50 mm
Mounting Style	Adhesive
Packaging Type	PET Film
Randome Color	Black

LumenRadio order code: 104-1008



Microchip Technology, 0.56 dBi whip monopole antenna

The Lumen Radio 0.5 dBi whip antenna is a high-efficiency compact antenna with exceptional performance characteristics. The antenna is of small size 28.4 mm long which can fit with small size products. Together with MWA-N3 the total maximum radiated power is 20.06 dBm (101.4 mW).

Electrical Specifications

Frequency Range	2400-2500 MHz
Gain	0.56 dBi
V.S.W.R	<1.3
Nominal Impedance	50 Ohm
Connector	RP-SMA Male
Length	28.4 mm
Randome material	TPEE
Randome Color	Black

LumenRadio order code: 104-1034



LumenRadio, 5 dBi outdoor puck antenna

The LumenRadio 5 dBi dipole omnidirectional antenna is well-suited for products enclosed within metal shield. The antenna comes with a 1 m long RG-174 cable terminated with a RP-SMA male connector. Together with MWA-N3 the total maximum radiated power is 24.5 dBm (281.8 mW).

Electrical Specifications	
Frequency Range	2400-2483.5 MHz
Gain	5 dBi
V.S.W.R	<1.5
Nominal Impedance	50 Ohm
Polarization	Vertical
Max Power	25 W
Connector	RP-SMA Male
Length	1 m
Height	Ø 45 * 25 mm
Random material	ABS
Random Color	Black

LumenRadio order code: 104-1033



Note: The following antennas are not tested against FCC and IC regulatory requirements and are not approved to be used with MWA-N3 in the North American market:

TE Connectivity, 3.2 dBi dipole antenna

The TE Connectivity dipole 3.2 dBi antenna is a dome-type panel mount antenna that is available with different types of termination.

Electrical Specifications	
Frequency Range	2400-2483.5 MHz
Gain	3.2 dBi
V.S.W.R	<1.9
Nominal Impedance	50 Ohm
Max Power	5 W
Mounting Type	Panel Mount
Random Color	Black

Manufacturer order number: ANT-DB1-WRT-



TE Connectivity, 2.1 dBi monopole antenna

The TE Connectivity monopole 2.1 dBi antenna is a dome-type panel mount antenna that is available with different types of termination.

Electrical Specifications

Frequency Range	2400-2500 MHz
Gain	2.1 dBi
V.S.W.R	<2.2
Nominal Impedance	50 Ohm
Max Power	5 W
Mounting Type	Panel Mount
Random Color	Black

Manufacturer order number: ANT-DB1-WRT-MON-



Power supply recommendations

The MWA-N3 Module is designed for 3.3V operation. All pins should not have any power applied to them before the +3.3V rail is applied.

To ensure reliable operation, the supply pin should be decoupled with a 100nF ceramic capacitor close to the supply pin. It is also recommended to add a high value ceramic bulk capacitor, such as 47uF, which will reduce the current ripple of the 3.3V net.

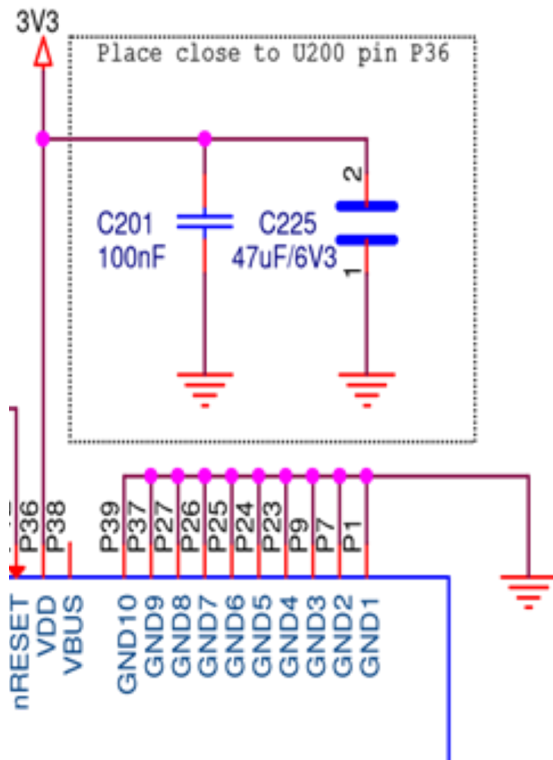

During radio transmission, current consumption will rise sharply to 150mA typical, 250mA max. A typical slew rate value is 300A/s during radio transmission.

Symbol	Parameter	Min.	Typ.	Max.	Unit
VDD	Supply voltage	3.0	3.3	3.6	V
Vrise	Supply rise time (0 V to 3.7V)			60	ms
IDD	Supply peak current capability		150	250	mA
IDD_rate	Supply current slew rate		300		A/s

Mechanical specification

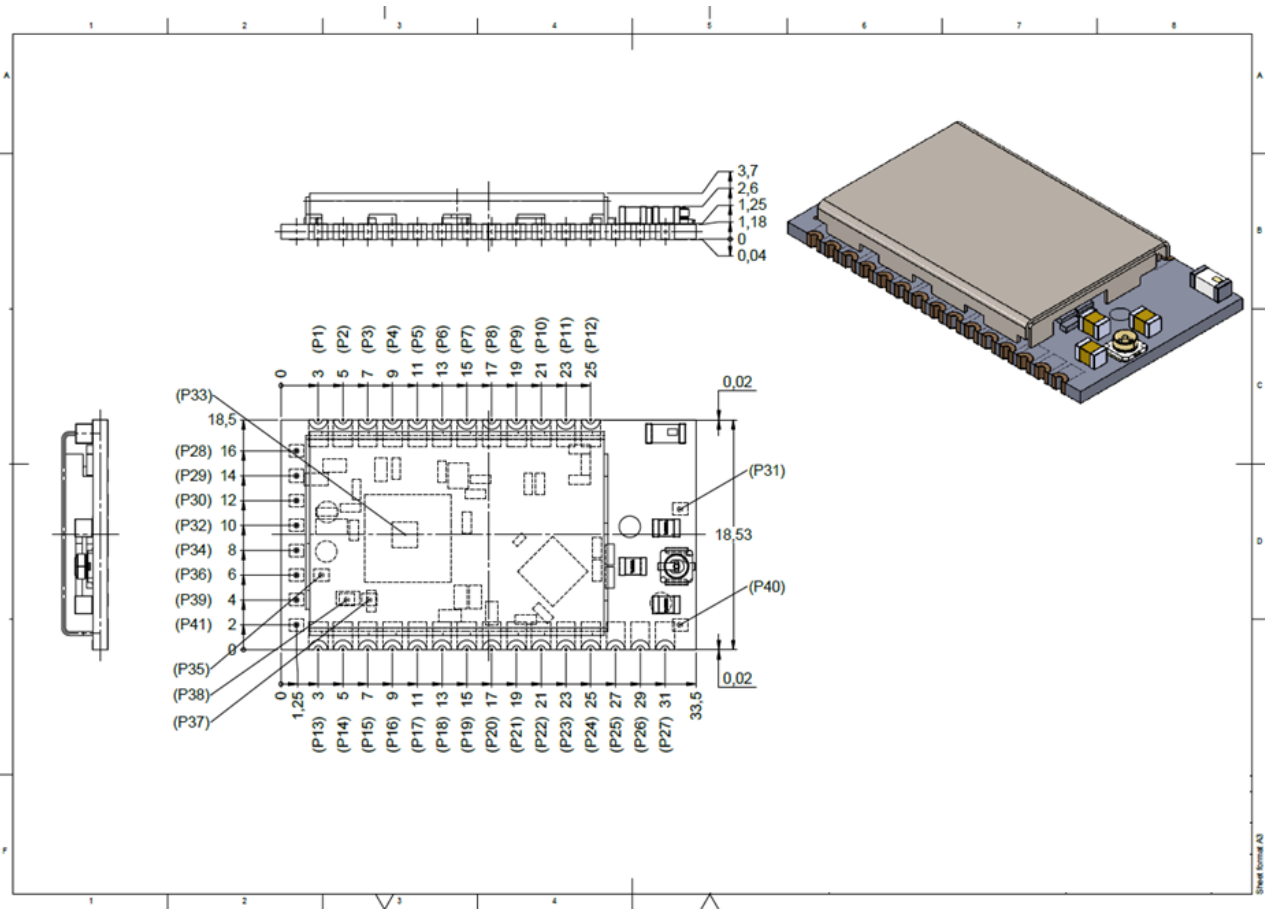

All dimensions in mm.

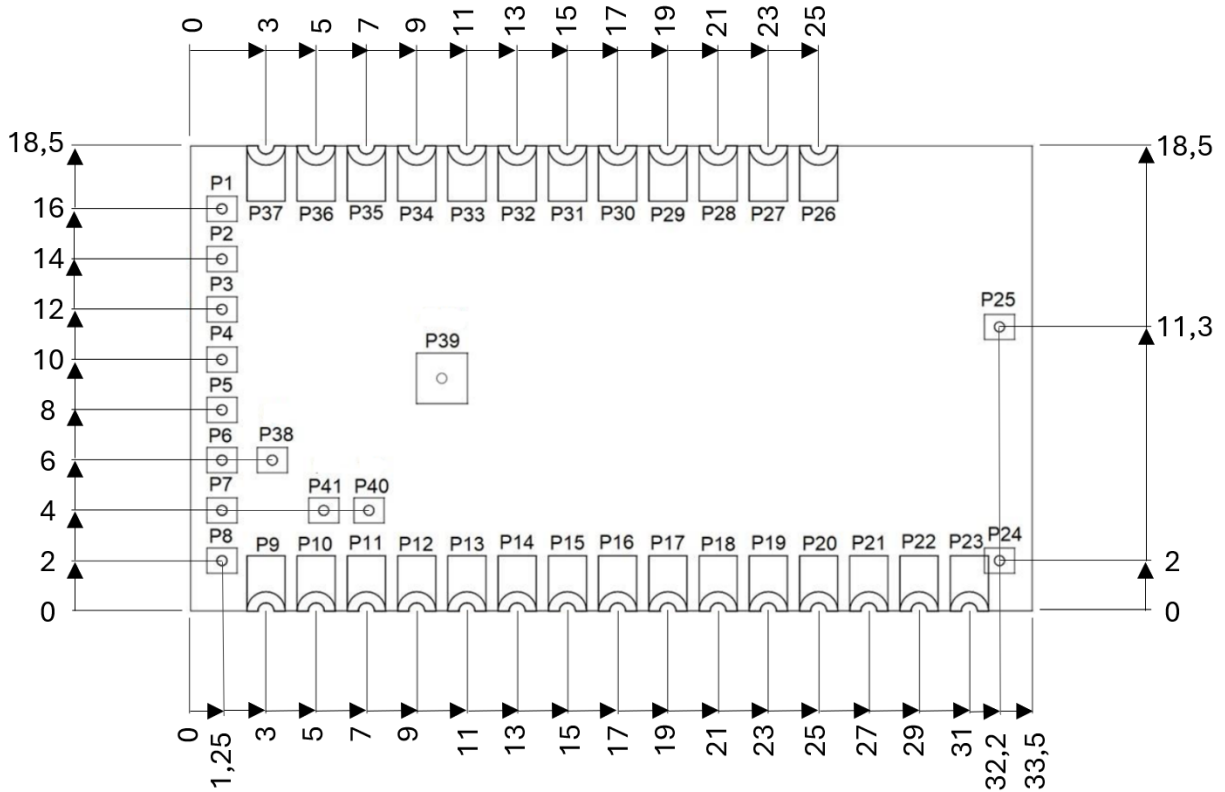

Refer to the picture above. All units in mm. All below positions are with respect to the origin point (0 , 0):

- Pin P38 position (3.25 , 6)
- Pin P39 position (10 , 9.25)
- Pin P40 position (7.1 , 4)
- Pin P38 position (5.3 , 4)

Mechanical design files in .stp and .dxf format is available for download at the LumenRadio online support page.

Reel marking

Every reel has an identifier sticker both on the reel and the reel package.



The identifier sticker contains the following information:

PRODUCT XXX-XXXX	SOFTWARE VERS. SW: XXXX		
PACKED DATE XXXX-XX-XX	XX:XX:XX	QUANTITY XXX	
XXXXXX (serial number)			

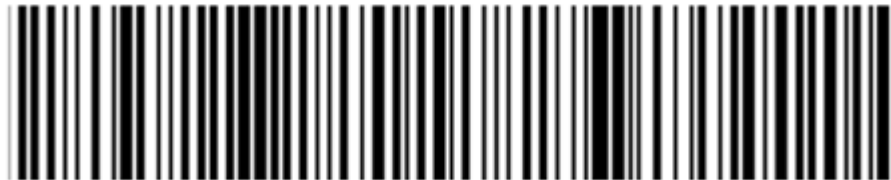

FCC ID: XRSTIMOMWAN301
IC ID: 8879A-TIMOMWAN301



Reflow soldering specification

The MWA-N3 module is a surface mounted device (SMD) designed to be easily integrated into high-volume production lines including reflow soldering to a PCB. It is ultimately the responsibility of the customer to choose the appropriate solder paste and to ensure oven temperatures during reflow meet the requirements of the solder paste. The MWA-N3 module conforms to JSTD-020D1 standards for reflow temperatures.

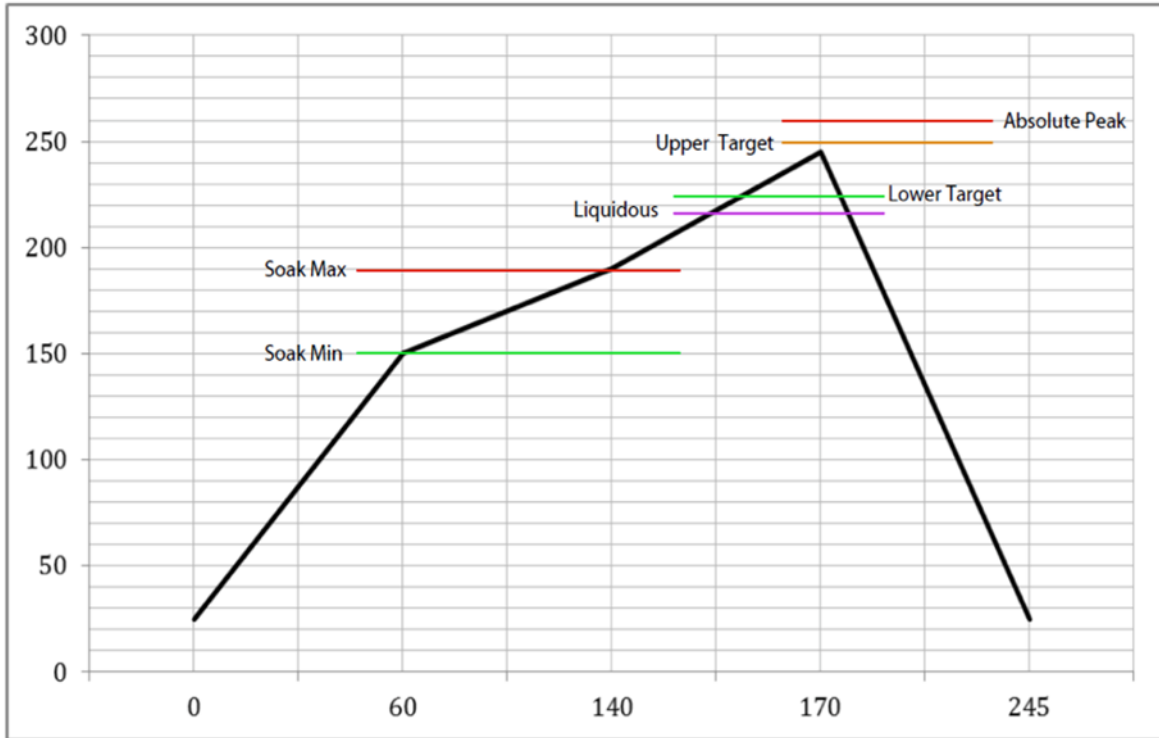

Temperatures should not exceed the minimums or maximums presented in the table below

Specification	Value	Unit
Temperature Inc./Dec. rate (max)	3	°C/s
Temperature Decrease rate (target)	2-3	°C/s
Soak Temp increase rate (goal)	0.5-1.0	°C/s
Flux soak period (min)	70	s
Flux soak period (max)	120	s
Flux soak temp (min)	150	°C
Flux soak temp (max)	190	°C
Time above Liquidous (min)	50	s
Time above Liquidous (max)	70	s
Time in target reflow range (goal)	30	s
Time at absolute peak (max)	5	s
Liquidous temperature (SAC305)	218	°C
Lower target reflow temperature	225	°C
Upper target reflow temperature	250	°C
Absolute peak temperature	260	°C

Product verification guideline

FCC information

MWA-N3 FCC ID: XRSTIMOMWAN301

Federal Communication Commission Interference Statement

This equipment has been tested and found to comply with the limits for a Class B digital device, pursuant to Part 15 of the FCC Rules. These limits are designed to provide reasonable protection against harmful interference in a residential installation. This equipment generates, uses and can radiate radio frequency energy and, if not installed and used in accordance with the instructions, may cause harmful interference to radio communications. However, there is no guarantee that interference will not occur in a particular installation. If this equipment does cause harmful interference to radio or television reception, which can be determined by turning the equipment off and on, the user is encouraged to try to correct the interference by one of the following measures:

- Reorient or relocate the receiving antenna.
- Increase the separation between the equipment and receiver.
- Connect the equipment into an outlet on a circuit different from that to which the receiver is connected.
- Consult the dealer or an experienced radio/TV technician for help.

IMPORTANT NOTE:

In the event that these conditions cannot be met (for example certain laptop configurations or co-location with another transmitter), then the FCC authorization is no longer considered valid and the FCC ID cannot be used on the final product. In these circumstances, the OEM integrator will be responsible for re-evaluating the end product (including the transmitter) and obtaining a separate FCC authorization.

End Product Labelling

This transmitter module is authorized only for use in device where the antenna may be installed such that 20cm may be maintained between the antenna and users. The final end product must be labelled in a visible area with the following: "Contains FCC ID: XRSTIMOMWAN301".

Manual Information to the End User

The OEM integrator has to be aware not to provide information to the end user regarding how to install or remove this RF module in the user's manual of the end product which integrates this module. The final host product still requires Part 15 Subpart B compliance testing with the modular transmitter (MWA-N3) installed.

Industry Canada statement

IC: 8879A-TIMOMWAN301

This device complies with Industry Canada licence-exempt RSS standard(s). Operation is subject to the following two conditions:

- this device may not cause interference, and
- this device must accept any interference, including interference that may cause undesired operation of the device.

Le présent appareil est conforme aux CNR d'Industrie Canada applicables aux appareils radio exempts de licence. L'exploitation est autorisée aux deux conditions suivantes:

- l'appareil ne doit pas produire de brouillage, et

- l'utilisateur de l'appareil doit accepter tout brouillage radioélectrique subi, même si le brouillage est susceptible d'en compromettre le fonctionnement.
FCC Caution Any changes or modifications not expressly approved by the party responsible for compliance could void the user's authority to operate this equipment. This device complies with Part 15 of the FCC Rules. Operation is subject to the following two conditions:
- This device may not cause harmful interference, and
- This device must accept any interference received, including interference that may cause undesired operation.

FCC Declaration of Conformity

We LumenRadio AB, Johan Willins Gatan 6, 41648 Gothenburg, Sweden, declare under our sole responsibility that Mira MWA-N3 comply with Part 15 of FCC Rules.

FCC Radiation Exposure Statement

This equipment complies with FCC radiation exposure limits set forth for an uncontrolled environment. This equipment should be installed and operated with minimum distance 20cm between the radiator and your body. This transmitter must not be co-located or operating in conjunction with any other antenna or transmitter. This device is intended only for OEM integrators under the following conditions:

- The antenna must be installed such that 20 cm is maintained between the antenna and users
- The transmitter module may not be co-located with any other transmitter or antenna

Caution Exposure:

This device meets the exemption from the routine evaluation limits in section 2.5 of RSS102 and users can obtain Canadian information on RF exposure and compliance.

Le dispositif répond à l'exemption des limites d'évaluation de routine dans la section 2.5 de RSS102 et les utilisateurs peuvent obtenir des renseignements canadiens sur l'exposition aux RF et le respect.

This equipment should be installed and operated with a minimum distance of 20 centimeters between the radiator and your body.

Cet équipement doit être installé et utilisé avec une distance minimale de 20 centimètres entre le radiateur et votre corps.

The final end product must be labeled in a visible area with the following:

The Industry Canada certification label of a module shall be clearly visible at all times when installed in the host device, otherwise the host device must be labelled to display the Industry Canada certification number of the module, preceded by the words "Contains transmitter module", or the word "Contains", or similar wording expressing the same meaning, as follows:

Contains transmitter module: 8879A-TIMOMWAN301

where 8879A-TIMOMWAN301 is the module's certification number.

CE

Mira MWA-N3 comply with the Essential Requirements of RED (Radio Equipment Directive) of the European Union (2014/53/EU). Mira MWA-N3 meet the ETSI EN 300 328 V2.2.2 conformance standards for radio performance.

Other compliances

For other local compliance regulations (CE, UL, CSA, SRRC, C-Tick, etc.) you are responsible as the product manufacturer to ensure all required compliance testing is completed. LumenRadio are happy to advise on compliance testing – please contact LumenRadio for details.

RoHS / REACH

The MWA-N3 module complies with directive 2011/65/EU, 2015/863/EU (RoHS) of the European Parliament and the Council on the restriction of the use of certain hazardous substances in electrical and electronic equipment. The MWA-N3 module modules do not contain the SVHC (Substance of Very High Concern), as defined by Directive EC/1907/2006 Article according to REACH Annex XVII.

Radio validation tool

The purpose of this tool is to evaluate RF performance. It can be used to certify for both the ETSI and FCC standards. The tool is also helpful during hardware development to verify the RF behaviour. To be able to use the radio validation tool, you need to have access to the serial debug and programming pins of the module see pin assignment in order to upload the radio test FW using J-Link. The radio validation tool is available for download at the LumenRadio online support page.

Contact and ordering information

LumenRadio AB
Johan Willins Gatan 6
SE-416 48 Gothenburg
Sweden
Phone: +46 31 301 03 70
www.lumenradio.com
sales@lumenradio.com

The LumenRadio support team can be reached through our support portal.

Product	Order code
MWA-N3 module 400pc reel	800-8205
LumenRadio, 2.15dBi dipole antenna	104-1001
u.FL to RP-TNC female 15cm	102-2006